

Touch Side View

CONNECTOR PINOUT	
PIN#	DESIGNATION
1	Shielding
2-16	Blank
17-48	Y32-Y1
49	Blank
50-51	Grounding Line
52	Blank
53-107	X1-X55
108-119	Blank
120	Grounding Line

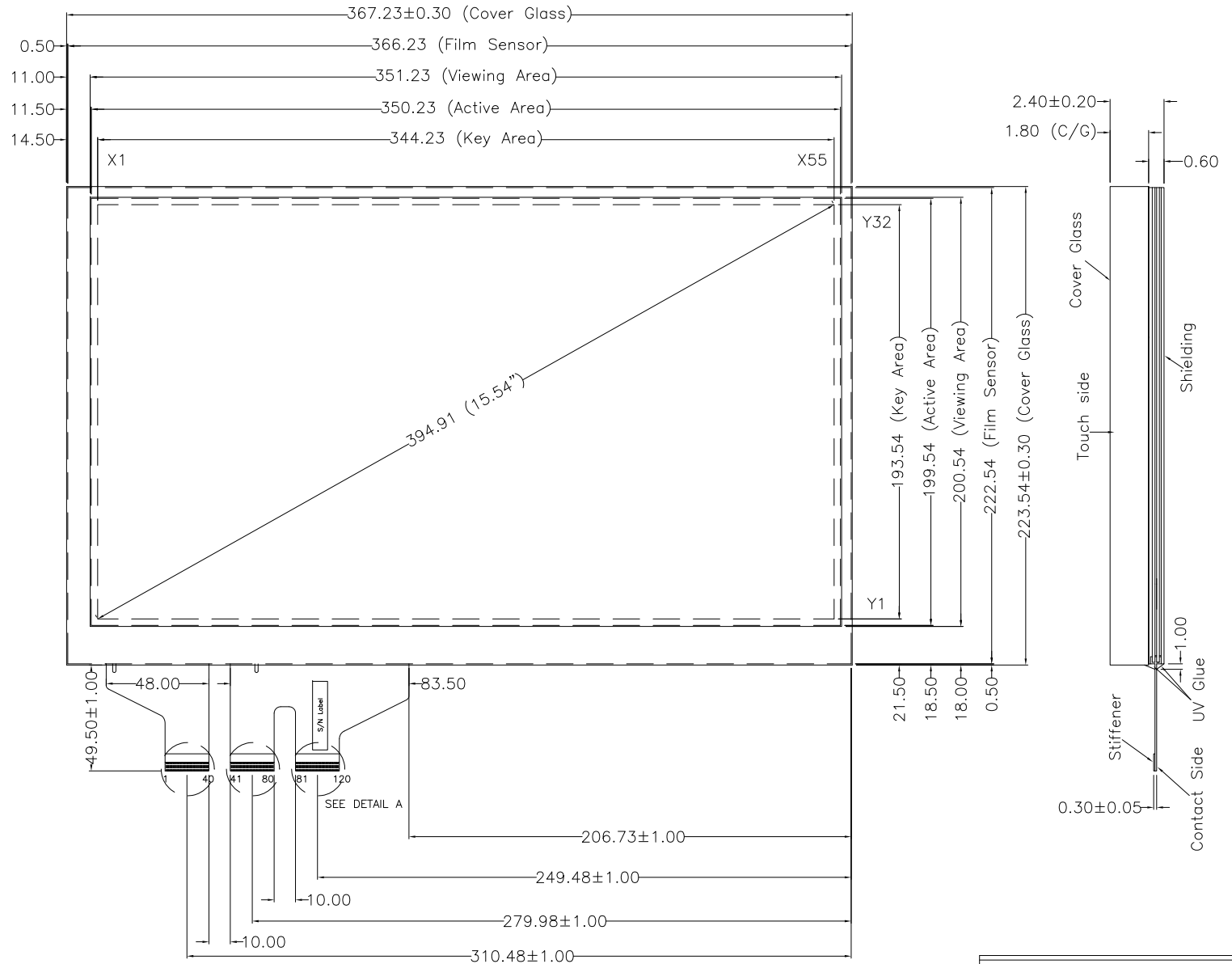
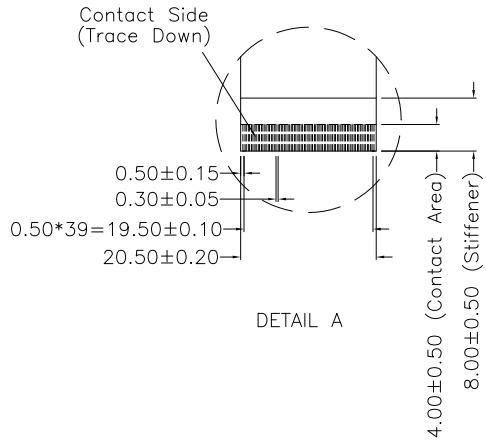

NOTES:

1. INPUT MODE : PROJECTED CAPACITIVE
2. OVERALL THICKNESS : 2.40±0.20mm
3. COVER GLASS THICKNESS : 1.80mm
4. FRONT SURFACE : CLEAR TYPE
5. TAIL TYPE : GOLD PLATED FPC , ZIF
6. RECOMMENDED CONTROL BOARDS : PENMOUNT PM1500 SERIES
7. OTHER SPEC : SEE APPROVAL SHEET
8. PLEASE REFER TO AMT TOUCH SCREEN INTEGRATION GUIDES FOR SYSTEM MECHANICAL DESIGN AND ASSEMBLY METHODS



NO.	DATE	DESCRIPTION	CHK
REVISION			
CHIEF OF DESIGN		APPROVED	Jerry
ENGINEER		PROJECT MANAGER	
DRAWN BY	Andre	DATE	JUN 24 , 2013
SHT	1	OF	1
		REV.	0

Apex Material Technology Corp.		
TOLERANCES UNLESS SPECIFIED		MODEL NAME : P3016-02
.X	± 0.50	DWG NO : P3016-02-0-011
.XX	± 0.50	SCALE: N/S UNIT: mm
.XXX	± 0.30	
ANGULAR	.	